



D8 D6

OFF-HIGHWAY MULTI-VIEW DUMPER TRUCKS



**THE MOST COMPACT**



## Technical data

<b>DONNÉES GÉNÉRALES</b>		<b>D8</b>	<b>D6</b>
Charge utile	kg	8.000	6.000
Capacité caisson niveau d'eau	l	3.200	3.200
Capacité caisson à ras	l	4.600	4.600
Capacité caisson à dôme	l	6.100	6.100
Système de déchargement		Postérieur	Postérieur
Poste de conduite		Réversible - Dual View	Réversible - Dual View
Châssis		Fixe	Fixe
Poids à vide	kg	5.100	5.100
Transmission		Hydrostatique	Hydrostatique
Cabine		Rops-Fops	Rops-Fops
<b>*MOTEUR</b>			
Marque		Yanmar	Yanmar
Modèle		4TNV98CT-NYI2D	4TNV98CT-NYI2D
Puissance	kW	53,7	53,7
<b>CARACTERISTIQUES DE CONDUITE</b>			
Vitesse maximale	km/h	25 (40 opt.)	25 (40 opt.)
Pente franchissable	%	50	50
Rayon de braquage	mm	4400	4400
Traction		AWS	AWS
Pneumatiques		12.5/80-18 16 PR	12.5/80-18 16 PR
Verrouillage oscillation essieu		Optional	Optional
<b>CIRCUIT HYDRAULIQUE</b>			
Circuit hydraulique		Pompe à double engrenage	Pompe à double engrenage
Pression de travail	bar	180	180
<b>CIRCUIT ÉLECTRIQUE</b>			
Démarrreur	V/kW	12/3	12/3
Batterie	V/Ah	12/110	12/110
<b>CAPACITÉ RÉSERVOIR</b>			
Carburant	l	125	125
Hydraulique	l	125	125
<b>FREINS</b>			
Service		Hydraulique agissant sur les deux essieux	
Stationnement		Action hydraulique sur les essieux arrière	
<b>HOMOLOGATIONS</b>			
Homologation routière (italienne)		Oui	Oui

\*Moteur Stage IIIA disponible

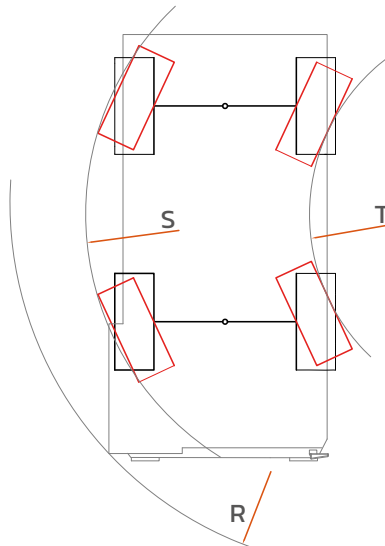
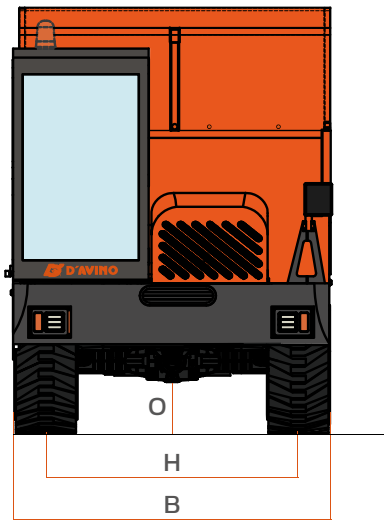
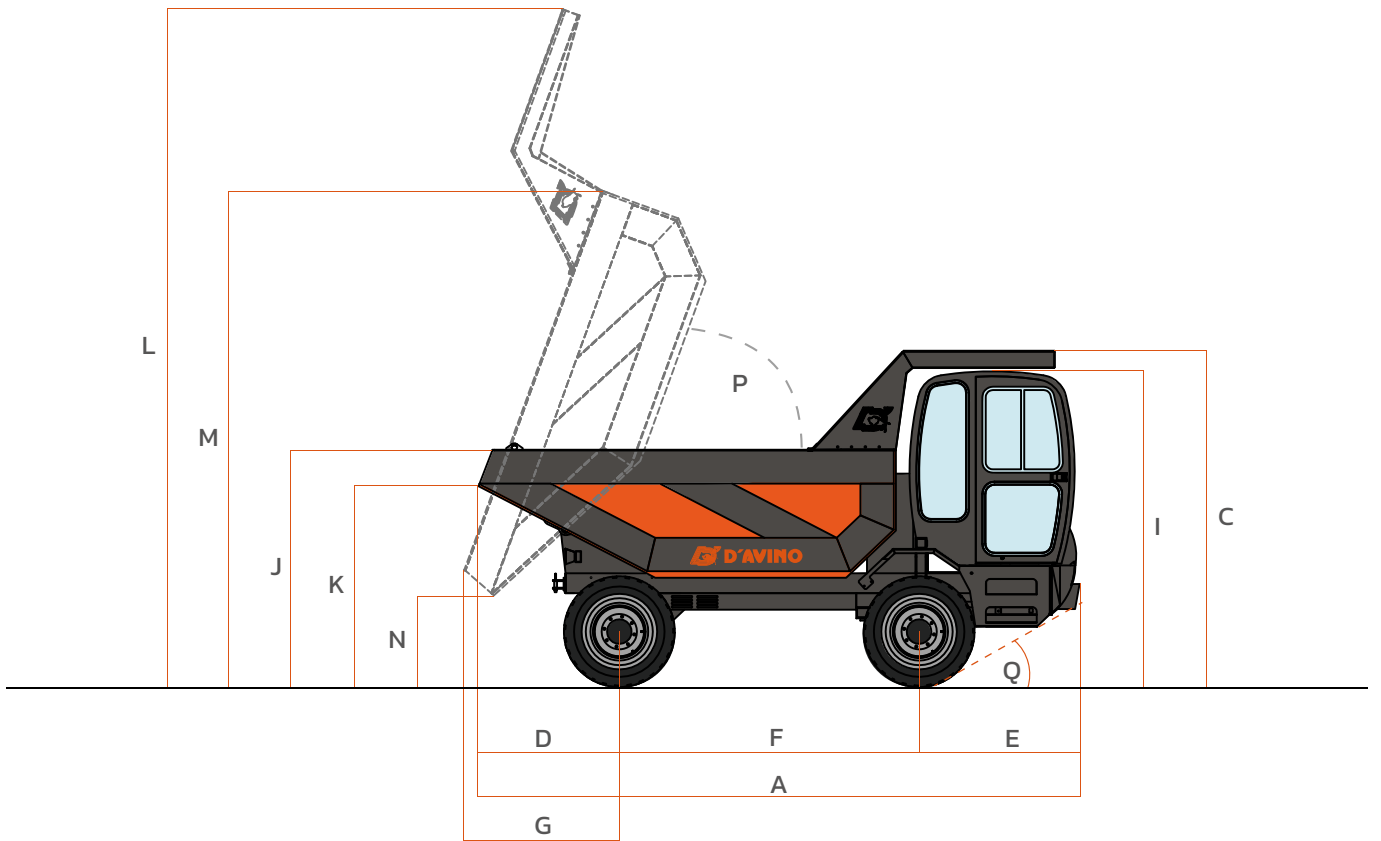

	<b>D8</b>	<b>D6</b>
<b>A</b>	4645	4645
<b>B</b>	2000	2000
<b>C</b>	3170	3170
<b>D</b>	1230	1230
<b>E</b>	1285	1285
<b>F</b>	2130	2130
<b>G</b>	1490	1490
<b>H</b>	1665	1665
<b>I</b>	2780	2780
<b>J</b>	2280	2280
<b>K</b>	1865	1865
<b>L</b>	5530	5530
<b>M</b>	3560	3560
<b>N</b>	880	880
<b>O</b>	300	300
<b>P</b>	70°	70°
<b>Q</b>	31°	31°
<b>R</b>	4400	4400
<b>S</b>	4000	4000
<b>T</b>	2000	2000



AMOG srl | I-80031 Brusciano (NA) | Tel. +39 081 658 8361 | [sales@davinogroup.biz](mailto:sales@davinogroup.biz)

[davinodumper.com](http://davinodumper.com)